



Compost production in developing countries: case study

Martin Pépin Aina^{1*}, Biaou Dimon¹, Daniel Chougourou¹, Hontonho E. Justine Deguenon¹, Flora Adjahatode¹, Mansourou Moudachirou¹, Florence Charnay², Guy Matejka²

¹Laboratoire des Sciences et Techniques de l'Eau de l'Ecole Polytechnique d'Abomey Calavi. Université de Abomey-Calavi 01 BP 2009 Cotonou, Benin

²Groupe de Recherche Eau Sol Environnement – Ecole Nationale supérieure D'ingénieur de Limoges, Ester Technopole 87 068 Limoges Cedex, Benin

Received: 18 August 2012

Revised: 18 September 2012

Accepted: 19 September 2012

Key words: Compost, quality, maturity, heavy metals, trace elements.

Abstract

Facing the problems connected to the wrong management of urban wastes, a few Developing Countries (D.C.) have set up the industry of processing household refuse through composting. However the compost produced is not assessed, its quality and promotion next to farmers are not ensured. This work intends to assess the quality of compost produced on a site so as to make a qualitative comparison. In view of the results, it has been noticed that in the compost, the majority of the metals seen are located in the slenderest fractions. The humidity content is weak or low along the whole process of degradation. The pH is stabilized between 7 and 8. The nitrate content increases progressively and the ammonium content reaches a maximum after fifteen days of fermentation. Solvita®'s test result for the « coarse » compost is of 4 (young compost), very active and immature and for the « fine » compost of 3 (very active compost), young material with high rate of breathing. They are in the process of degradation according to the scale of 8 (mature compost). The compost shows then a slice phyto-toxicity due to a lack of maturation of the product. The fine compost which doesn't show any pathogenic agent (*E. coli* and *Shigella*). The latter is then hygienized. Therefore, the result of all this is that, the process at the current stage, produces a compost of an average agronomical quality.

*Corresponding Author: Martin Pépin Aina ✉ marnickson@yahoo.fr

Introduction

Composting is a method of biological aerobic treatment of wastes. Composting is described as biological by the intervention of micro-organisms in the degradation of the organic matter in the waste and as hygienic by the rise of temperature destroying pathogenic germs and viruses. A few weeks to a few months of natural decomposition turn the organic wastes into a product, the compost that can be used as fertilizer for agricultural soils (Matejka *et al.*, 2001, Zurbbrugg *et al.*, 2005, Rivero *et al.*, 2004)

To use this process at the industrial scale, it is necessary to know perfectly the different physicochemical factors and the microbiological contributors. Besides, the obtained compost must correspond to the standards of quality fitting themselves the requirements of the consumers and of the market (Wei *et al.*, 2000). In the absence quality criteria and of quality insurance systems specified by the legislation of developing countries, the ones under regulation in industrialized countries are sometimes taken as reference (Bionet, 2002). The quality obtained is mainly dependent on the nature of the initial products used and the monitoring of the physicochemical parameters. The majority of physical and qualitative parameters give some information about the stage of fermentation rather than the stage of maturity of the compost.

The majority of studies about the stage of maturity of composts are based on the progress of the global physicochemical parameters: pH, ratio C/N and ratio $\text{N-NO}_3^-/\text{N-NH}_4^+$, ability to exchange cations (A.E.C)... Immature composts are distinguished by the acid pH. The mature composts have a pH neighboring neutrality or higher (between 7 and 9) [Avnimelech *et al.*, 1996]. The process of humification produces functional groups and increases the oxydation of the organic matter, bringing about an increase in the ability to exchange cations (A.E.C). The monitoring of that parameter also helps to assess the compost maturity. Harada

and al., 1981 suggest a value of A.E.C higher to 60 mg eq/ 100 g of compost.

The ratio C/N is the parameter most commonly measured to assess compost maturity. It may be determined either during the solid or the liquid phase when put into contact with water. [Bernal and al., 1998]. The ratio C/N inferior to 12 during the solid phase is regarded as maturity indicator for the compost. (Iglesias-Jimenez *et al.*, 1993). That ratio often found is brought closer to the C/N ratio, close to 10, of soils with humus. The majority of the nitrogen content in the compost is from organic origin and like proteins or simple peptides. A low quantity of nitrate ions is mineralized into ammonium ions by the process of ammonification as a consequence of the bacterial activity. The ions thus formed are going to react differently according to the nature of the substratum: they are immobilized by the microorganisms, then they are changed into organic nitrogen or they are volatilized et degased during an increase of temperature (Sanchez-Monedero *et al.*, 2001). A study by Sanchez-Monedero *et al.*, (2001) came to the conclusion that the loss of nitrogen in a house refuse compost is close to 40% and that a ratio $[\text{N-NH}_4]/[\text{N-NO}_3]$ less or equal to 0.11% corresponds to an indicator of maturity for that kind of compost. The organic nitrogen of the stabilized compost is slowly mineralized at a speed similar to the one of soils (0.26 mg N/kg/j) without evolution according to the age of the compost. For less stable composts, the speed of mineralization is higher (0.4 mg N/kg/j) [Houot *et al.*, 2002]. The quality of the compost is also assessed by nitrogen monitoring. In fact, the microorganisms nitrify the substratum resulting in a drop of the concentration of $[\text{NH}_4^+]$ and an appearance of nitrate ions.

The phyto-toxicity tests are the only means to assess compost toxicity in the soils. An immature compost contains phyto-toxic products such as phenolic acids or volatile fatty acids. (Kirchmann and Widen, 1994 in Bernal, *et al.* 1998). Numerous phyto-toxicity tests can assess compost maturity but the

most frequently found in literature and in practice are the:

- Tests of plants' growth (Helfrich *et al.*, 1998 ; Garcia *et al.*, 1992 ; Hirai *et al.*, 1986),
- Tests of germination (Garcia *et al.*, 1992 ; Wu *et al.*, 2000),
- Test of roots development (Brinton, 2000).

Very often, many parameters are necessary in the determination of compost maturity. In the industrialized countries where the regulation and the quality criteria are strict, a distinction is made between the different qualities of composts: mature, cold or mulch. Most of Developing Countries do not have any regulation as far as compost quality is concerned. Among the criteria of quality, the content in heavy metals is always recommended in the regulations.

The heavy metals contents in the compost are very changeable from one country to the other. The main sources of heavy metals in urban composts are often common to urban wastes : batteries (Hg, Zn, Pb, Cd), paints (Cr, Cd, Pb), plastics (Cd, Ni, Zn), paper cardboards (Pb), electronic components (Pb, Cd), pottery, cosmetics (Aina *et al.*, 2009; Miquel, 2001; Meoun & Le Clerc, 1999). That's why the extraction of toxic metallic elements is an essential step in the composting industry since it conditions the content in heavy metals, therefore the quality of the compost.

The quality of compost is also judged by its ability to better soil fertility. The compost allows a low mobility of nutrients especially nitrogen. This means that the mineralization will only release 5 to 20% of total nitrogen in compost during the first year. However, it ensures later on, a continuous availability of nitrogen. Two parameters are assessed: the compost ability to supply soils with nutritious elements and its amending value. A good supply of trace elements such as phosphore, potassium, magnesium, and calcium, is brought by urban wastes compost.

Comparison tests have confirmed the beneficial effect of compost for cultures, when used alone or together with chemical fertilizers or dung. The increase of potato production in Guinea is of about 50% for compost application only (Matejka *et al.*, 2001). Its use together with other amendment or chemical fertilizers triples production outputs.

Materials and methods

Area of study

The site corresponds to an agglomeration of many millions of inhabitants. Although the country's, the closeness to the sea, gives it a Mediterranean climate. During that period, a wind generates dust and burning sand storms, the latter coming to modify the wastes' composition.

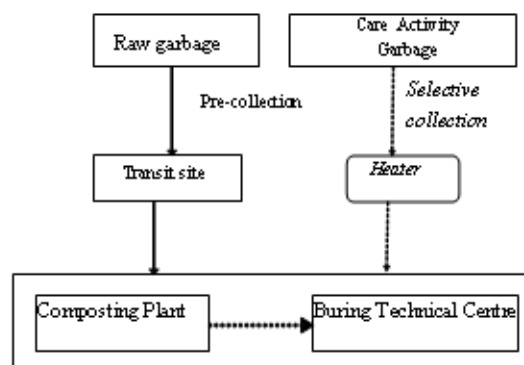

Fig. 1. Diagram of the city wastes management.

The plant's equipment are:

Reception wharf,

Orting out carpet with magnetic removal of iron scraps

(dimension (L*l) : 1*34 m, speed : 28 m/min),

Rotating pipe of type Dano ® - (dimension (L*l) : 3*11.5 m, speed : 10 tr/min),

55 mm round stitch Trommel - (dimension (L*l) : 3*2.5 m, speed : 10 tr/min),

14 mm round stitch vibrating table

Recyclable matters (glasses, plastics, cardboard) are separated. Following the passage of the wastes through the rotating pipe, of which the jigger is of 55 mm stitch, the wastes are put in swathe by a conveyor. A magnetic pulley helps to eliminate the ferrous components from the jigger discharges. The average dimensions (length, base width, height) of a

swathe , at the beginning of fermentation are respectively 410*3*1.5 m. Fermentation takes 21 days . Mechanical reversals take place every five days at the same time with the watering so as to maintain 50% humidity. The compost thus obtained is called compost « coarse » (stitch < 55mm), and often sold as it was. On request, the plant can also manufacture compost called « fine » of a grains' texture inferior to 14 mm The plant is proportioned for an average output of 10 T/h of urban wastes and its functioning is framed in Fig. 2.

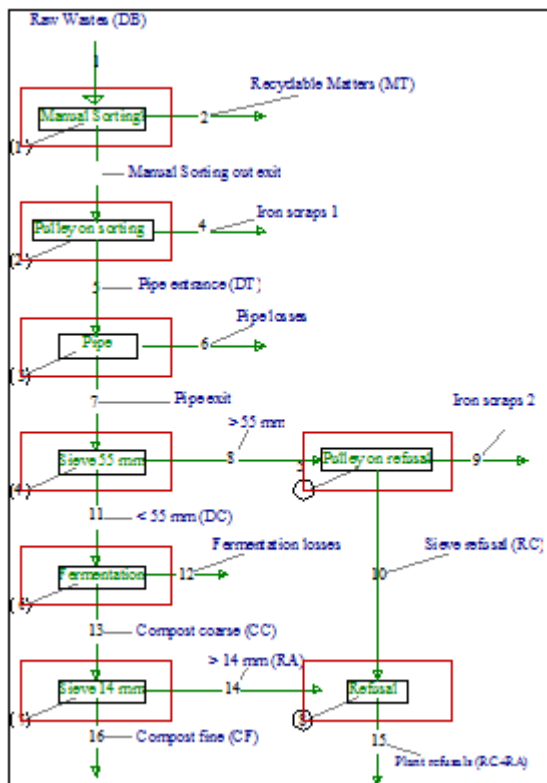

Fig. 2. Diagram of the plant's functioning.

The key points of the plant correspond to the operations carried out beforehand and further down the line at each stage, with the analysis of the discharges in some cases. All the stages of the process are studied. Those points are named according to the nature of the sample: wastes, materials, discharges, or compost and of their state at the level of the process as raw, sorted out , fermented,... for the continuation of the study, only the initials and the flux indicated in the previous key will be used.

The plant functioning diagram separates all the stages including the ones of the passage the wastes into the pipe, comprising the homogenization in the latter and the jiggling in the trommel. That plant processes from 200 to 220 T/day of urban wastes and manufactures 120 T of compost / day.

Sampling

Sample taking is crucial. When carried out in good conditions, it helps to avoid later on the mistakes of interpretation. The protocol of sample taking must help to have a representative sample of all the wastes entering the plant the D day. For that, the samples taking of each truck getting onto the plant are made all day long. A pot of mechanic shovel full of about 1 m³ of wastes taken from each truck, then the wastes are unloaded on a sorting out area, clean, with sheltered and shady sides. That area is preferably composed of a concrete slab, limiting contamination of the wastes by sand. The remaining content of the truck is unloaded onto to reception area. That handling is renewed for each truck. The thin elements are got back on the ground after the sampling and returned back. The total sample obtained is weighed, mixed up, then quartered for the analyses in order to obtain a quantity nearing 500 Kg. A sample is taken every hour, at exit of the stage checked. The quantity to be taken depends on the stages. The wastes in the process of treating correspond to an average sample comprising 10 sample takings of about 50 Kg got back the day long an aleatoric way. The sample is weighed, mixed up with the sample takings then quartered so as to obtain the quantity needed for the analyses. The wastes are much more homogenous, since they have undergone treating such as separation from recyclable wastes or a granulometric separation. The quantities taken are spaced out between 100 and 200 Kg so as to achieve the characterizations on dried wastes and on wet wastes. The standard (NF U 44-101) sets the methods of sampling of a batch of organic enriching agents or of a sequence of culture. The objective is to obtain the most representative sample. Taken as a whole, the method appeals to an aleatoric sample taking of 1 Kg then the use of the

quartering method. Literature analysis reveals practically, as many techniques of sample taking and samples preparations as techniques of studies. The taking carried out in the swathe fit an average sample in 10 points of 10 Kg, or more, taking into account the size of the swathe, with different depth (1 m, 1.5 m and 2 m). A taking is made half way of fermentation process (DA) to follow the evolution of degradation. After sample taking, the wastes are put in cloth bags and stored in a shaded area or even better in an Air- conditioned flat at 20°C. the storage time mustn't exceed 3 days under tropical climate, above that time limit, the deterioration of the sample is too serious.

Computerized data processing

In order to discuss the different results obtained, the statistics parameters accepted will be the average, the standard deviation, the variance and the modal class. The average easily falls in with the algebraic calculations as well as the statistic tests. It is all the most significant that the series dispatching is symmetrical and the dispersion weaker. However, it is sensitive enough to the abnormal values, small or big. Dispersion parameters (standard deviation and variance) help to measure the gaps between the values and the average. Those parameters help to visualize the bigger or the less big dispersion of results. Ces paramètres permettent de visualiser la plus ou moins grande dispersion des résultats. Finally the modal class is the class having the biggest size. (It represents the top of the peak while making size graphical representation = f (characters studied) if the values a normal law).

The results obtained during validation of the methodology are processed by a statistic method which assesses the margin of error between the standardized method and the new method. The « test of Student » is used to validate the method or not. Those tests are more and more used in biology. The rest on a simple principle : to make a choice among many possible hypotheses without having at one's disposal enough information to make the choice reliable. An initial hypothesis written down

(H_0), is checked. The value taken by that aleatoric variable is calculated at the end of the experiment. According to that information, the hypothesis is validated or not. If the result obtained leads to accept (H_0), the risk of error is written down α which stands for the probability of being mistaken when (H_0) is spaced. That risk is determined by the user of the test. The hypothesis is the following : under (H_0), if X follows a normal law, then the aleatoric value « t » follows the law of Student at a liberty degree $(n_1+n_2)-2$. In order to validate the hypothesis, it is compared to the value seen in the Table of Student, n_1 and s_1 being the average and the standard deviation of the results of the normed method, n_2 and s_2 the average and the standard deviation of the results of the method tested.

Results

Progress of the main parameters

Numerous parameters help to appreciate the evolution and compost maturity. The main parameters have been monitored at each stage of the process, for each granulometrical fraction and for each category of fermentescibles: loss in fire, C/N ratio, NaCl and some metals. The value of each one is brought back to the percentage of the corresponding flux, by weighing it with the granulometric percentage. In the course of this study, a sample of raw waste was omitted at the time of the sample taking, DB 20 to 50 mm, and a second one couldn't be checked because present in very low quantity less than 500 g and judged non representative, DC 100 to 50 mm. That's why in the results of the analytical parameters, a difference is noticed between the results obtained for the raw sample and the sum of granulometric fractions.

Total organic matter per loss of fire

The regulation in force in the country gives the minimum value of the total organic matter (T.O.M) content in the compost of dans 17%. Fig. 4 represents histograms per pairs: the first one shows the T.O.M content per granulometric fraction and the second one, the total content of the sample.

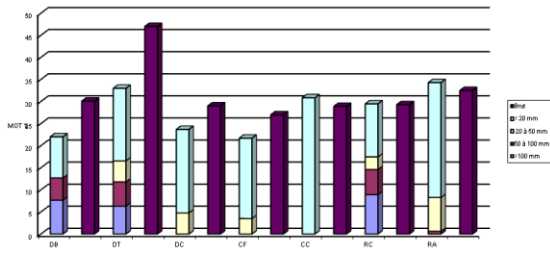

Fig. 3. Evolution of the total organic matter.

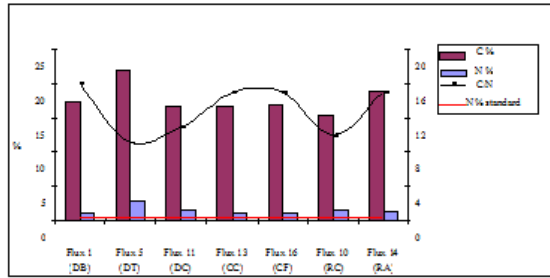

Fig. 4. Evolution of the C/N ratio.

The T.O.M content of wastes increases after the sorting out since some inorganic constituents are separated from the sample. The follow up of the process doesn't show a strong variation. Moreover, the majority of T.O.M. is in the fines < 20 mm and the sum of the granulometric fractions coincide with the flux reference value. The losses in T.O.M during the process are of the order of 30%, if we refer to the value of DT (and not DB). That loss is of the same order than the variations measured classically in literature. (Atkinson *et al*, 1996 ; Canet & Pomares, 1995 ; Iannotti *et al.*, 1994). The discharges contain non inconsiderable share of T.O.M, and are discarded by dumping. The T.O.M content generally seen in compost produced in developing countries is very variable, between 20 and 65% [Hafid, 2002 ; Dalzell *et al*, 1988]. That variation can be explained by the very nature of the composition the wastes composted, and also by the process and its functioning.

Ratio carbon/nitrogen

Carbon is assessed by a chemical method of oxidation with potassium bichromate, and nitrogen by kjeldahl method. The regulation in force gives a minimum value only for the nitrogen content in the compost of 0.46% which is always exceeded during the process as shown in Fig. 4.

The contents in organic carbon and nitrogen follow the same progress as the one of the T.O.M, that is to say an increase after the sorting out due to the separation of materials not very fermentescibles, then a slight decrease due to the separation of the discharges after the pipe. The C/N ratio is initially of 16, which is low for household refuse. According to literature, it might be placed between 30 and 40 [Sadaka & El Taweel, 2003 ; Mbuligwe *et al.*, 2002 ; Larsen & Mc Cartney, 2000]. That comes from the significant content in fibrous sugarcane residues composed of a significant nitrogen percentage.

Salt concentration NaCl

Salt, NaCl, is taken into account in the criteria pertaining to the regulation for compost quality. est pris en compte dans les critères de la réglementation pour la qualité du compost. The results of the analyses (Figure 5) indicate that the prescribed value of 5.5% has never been reached during the different stages of composting. That prescribed value of NaCl rate is in relation, on the one hand, with the location of the composting plant on the mediterranean coast, and on the other hand, with the cultures' irrigation method. In effet, the latters are watered with gound water laden with NaCl. It is then wise not to spread on agricultural soils a product with a high salt content.

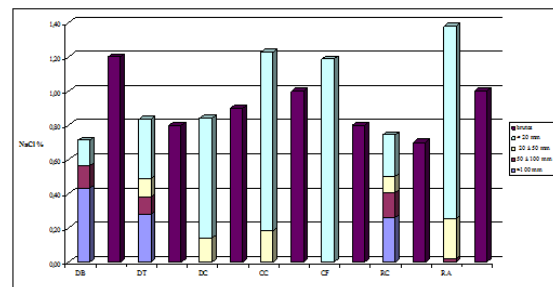

Fig. 5. Progress of NaCl concentration during composting on site B.

Salt content is mainly seen in fines < 20 mm; it is very low, between 0.70 and 1.40%. a gap is notable between the values of the raw sample and the sum of the ones obtained by granulometry, corresponding to error on the measurement.

Heavy metals

The purpose being to know the progress in metals content during the composting process, only a few metals, with specific characteristics have been selected. The cadmium and lead are toxic elements. They are frequently found in household refuse from developing countries because of their use as component elements of batteries. (Soumaré et al., 2003 ; Matejka *et al*, 2001 ; Sogreah, 2001 ; Soclo et al., 1999). Copper is an essential trace element for plants' growth, but toxic at some amount. Finally, iron serves as substance tracer since it is present in the wastes at relatively high proportions.

Table 1. Metals content expressed in mg/kg of MS.

	DB	DT	DC	CC	CF	RC	RA
Fe	204	212	242	4860	533	195	513
	0	5	5	0	0	0	0
Cu	123	49	304	329	356	240	277
Pb	468	276	187	1140	199	462	332
Cd	1	/	/	/	1	/	3

/ : Non detectible

Cadmium content is very low between 0 and 1 mg/Kg of dry matter and too close to the detection limit of the machine. Lead content is high in the jigger discharges and low for the substratum getting into fermentation. An increase in the metals content after the pipe is to be stressed. The granulometric reduction at the time of wastes passage into the pipe may be the cause of the contamination of samples of metals. For reference, the limit values of heavy metals content according to many legislations. The Project of French standards NF U 44-051 recommends as limit values a Cd content of 3 mg/Kg, a Cu of 300 mg/Kg and a Pb of 180 mg/Kg (others methods As, Hg, Ni, Cr, Se and Zn are also restricted). Only the lead content in composts produced are superior to the project's standards recommendations : that of the « coarse » compost seems however excessive, it is probably due to an error of sampling. The distribution of metals according to the granulometry is shown on the following pictures representing the progress of the concentration in metal considered in mg/Kg:

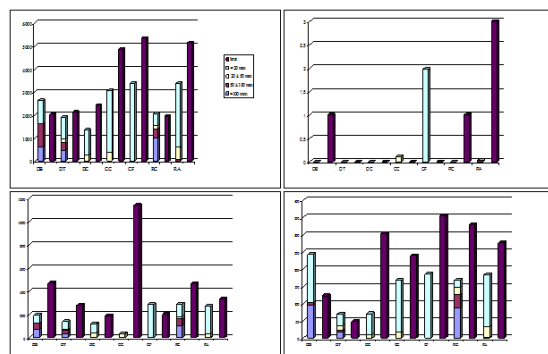

Fig. 6. Progress in Fe, Pb, Cu, and Cd contents in the different granulometric fractions during composting(mg/Kg).

In view of the results, one can notice that compost is charged in iron and copper during the process, this is mainly due to a phenomenon of concentration of slenderest fractions, the biggest ones disappear in favor of the weakest. In the compost, (CC, CF) the majority of the metals present are found in the slenderest fractions. As far as Pb is concerned, its concentration decreases when the process moves forward if the absurd value of CC is not taken into account. Cadmium monitoring not being precise, due to the method of measurement used, that indicator won't be taken into account in our case. But to be sure of compost quality and its harmlessness next to toxic metals, other metals, (Cr, Ni, Hg, As...) must be checked during the process. It is above all important to monitor toxic metals (Cr, Cd, Pb, Hg, As, Se).

Validity of findings

The above presented results correspond to characterizations on wet wastes. However, in the validation procedure of the methodology, a few samples from characterization on dry wastes have also been checked in order to make a comparison. The samples chosen are raw wastes for their heterogeneousness, a discharge, the one of refining, and also the two types of composts. The variability of the results obtained is shown on Table 6 with error percentage between the measurements obtained for the characterization on dry and the one of wet. The positive values correspond to stronger quantities of samples obtained by characterization

on dry matter, conversely, the negative values reflect stronger results achieving on wet matter.

The first notable remark is the high error percentage on the raw wastes coming from the heterogeneity of samples. It is important to notice that the percentages are calculated on the basis of the values measured on wet wastes. Thus the NaCl ratio shows big disparities whereas the measurements are spread out between 0 and 0.8%. The results are very different from a type of characterization to the other, mainly as far as raw wastes are concerned. Two factors can explain that:

firstly, the heterogeneity and then the bad representativeness of the sample taking; secondly the different composition of the wastes is being the result of the very nature of the type of characterization. For example the quantities of fermentescible matters. In conclusion, the samples stemming from a characterization on dry matter and the ones coming from a characterization on wet matter are hardly comparable. However, the method of characterization on wet wastes remains the more representative of the process.

Table 2. Error percentage on physico-chemical parameters between the characterization on dry matter and on wet matter.

<i>Difference dry-wet</i>	<i>Ashes %</i>	<i>C/N</i>	<i>OM%</i>	<i>NaCl%</i>	<i>Fe (ppm)</i>	<i>Cu (ppm)</i>	<i>Cd (ppm)</i>	<i>Pb (ppm)</i>
DB-100-00	7,0	150,0	25,4	-18,5	30,3	-62,2	0,0	1,3
DB-100-01	100,0	87,5	50,5	112,1	-71,4	-75,6	0,0	-24,2
DB-20,100-00	110,0	128,6	132,3	22,1	-49,5	-57,4	0,6	-43,3
DB-20,100-01	100,0	142,9	123,7	95,0	-63,4	-88,5	0,0	-4,2
DB-8-00	46,0	71,4	37,9	-27,9	-63,4	-67,6	0,0	65,2
CC-8,20-00	10,0	0,0	-13,6	7,0	-24,3	-32,7	0,0	0,7
CC-8,20-01	2,0	0,0	-34,7	43,5	-12183,7	-78,1	0,0	0,1
CC-8-00	-43,5	0,0	0,0	-30,0	-35,6	-31,5	0,0	72,8
CF-8,00	-32,4	0,0	-20,5	-166,7	-9,3	61,8	-100,0	49,6
RA-100,20-00	-4,3	0,0	-23,5	20,0	-47,0	-41,5	0,0	40,3
RA-100,20-01	-14,3	-6,7	22,9	38,9	-6,0	94,0	100,0	79,4
RA-8,20-00	-36,5	0,0	-34,2	-145,3	-2,3	-24,4	0,0	43,0
RA-8,20-01	-115,6	0,0	-18,2	-50,0	1,0	-56,0	0,0	50,8
RA-8,00	11,4	0,0	-54,6	34,9	-40,4	30,0	0,0	3,9
Min	-115,6	-6,7	-34,7	-166,7	-12183,7	-88,5	100	-43,3
Max	110,0	150,0	132,3	112,1	2101,9	149,2	100	287,2

Compost quality

Analyses have been carried out with objective of monitoring the degradation state of the wastes in the swathe during the fermentation stage. Global parameters, the nitrogen forms, and the maturity tests are made every 5 days at the moment of fermentation.

The global parameters

The global parameters of degradation such as the humidity, the pH and the temperature are shown on Fig. 7.

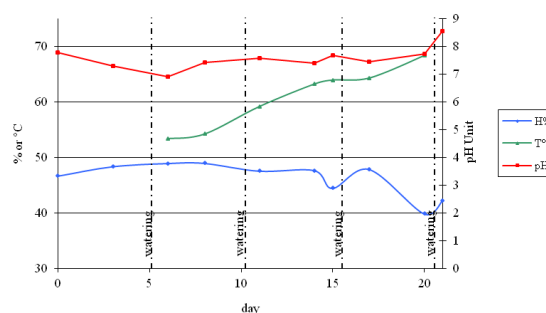

Fig. 7. Monitoring of the global parameters (H%, T°, pH) of fermentation in swathe.

The increase of the temperature doesn't show the characteristic drop due to the reversals [Mbuligwe *et al.*, 2002; Matejka *et al.*, 2001]. Moreover, it is in steady increase whereas the end of maturity is shown by a steady temperature neighboring outdoor temperature. On the other hand the duration and the values of the values of the temperatures reached correspond to the criteria required for hygienisation. (Noble & Roberts, 2003 ; Lucero-Ramirez, 2000 ; Deportes *et al.*, 1995). The closest measurements for example will help to better every two days, the monitoring of the temperature and to visualize the different stages of temperature increase. The humidity content is weak along the whole process of degradation, not exceeding the 50%. If the latter is readjusted around 60% (Ryst, 2001 ; Tiquia *et al.*, 1998), degradation will be make more rapidly with a probable higher temperature increase. pH is stabilized between 7 and 8 but it undergoes a slight increase around 9 the last day even though that increase must be stabized around neutrality close to 7-8 (Sanchez-Mondero *et al.*, 2001 ; Soclo *et al.*, 1999).

Nitrogen forms

The nitrogen forms checked are nitrates, nitrites, ammonium and organic nitrogen from the NTK. Analyses are carried out on an aqueous solution of compost at 5 g/L and the results are presented on Fig. 8.

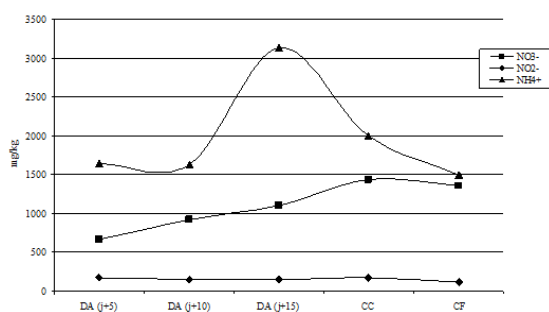

Fig. 8. Increase of nitrogen forms.

Nitrate content increases progressively and ammonium content reaches a maximum after fifteen days of fermentation. La teneur en nitrate augmente progressivement et celle en ammonium atteint un maximum après quinze jours de fermentation. That increase depends on the

alkalization stage: corresponding to a bacterial hydrolysis of nitrogen with ammoniac production (NH₃) combined with proteins degradation and organic acid decomposition, increasing the pH of the environment (Haug, 1993; Mustin, 1987). The monitoring of those parameters helps then to assess the degradation stages and to characterize the progress state of the porcess of degradation.

The simplified test of maturity assessment

Solvita® test is a colorimetric test of compost maturity assessment, depending on the operator for the perception of colors. In order to reduce errors, 2 operators have judged the colorimetric results of those tests shown on Table 7.

Table 3. Results of Solvita® tests.

Solvita®	NH ₃	CO ₂	Maturity index	Comments
DA (d+5)	6	2	2	Cold
DA (d+10)	4	5	5	Active
CC (d+20)	4	4	4	Active
CF (d+20)	4	3	3	very active

The results of Solvita® tests show a low progress of fermentation. The « coarse » compost reaches a maturity of (young compost), in the middle of degradation stage, very active and immature. The results of Solvita® test for the « fine » compost est of 3 (very active compost), young material with high breathing rate. They are in the cours of degradation according to a scale of 8 (mature compost). The jiggging stage, separating the fraction superior to 20 mm, seem to separate also part of the deteriorated organic matter since Solvita® maturity index decreases after that step. That method is more and more used in composting plants of developed countries. (Wang *et al.*, 2004 ; Francou, 2003 ; Changa, *et al.*, 2003 ; Brewer & Sullivan, 2003) Only a few examples are listed in literature for the case of developing countries. That limitation, for sure, stems from a lack of knoweledge about the product and its price (Ryst, 2001). Colorimetric tests of type Solvita® bring a reliable information on maturity state.

Cresson tests

Cresson germination tests have been made with “4 républicats”. The average percentage is represented in Table 8.

Table 4. Average of the results of cresson germination test.

Samples		% plant embryo At 2 days	% plant embryo at 7 days
DA J+5	Model	61	64
	Compost	0	6
DA J+10	Model	68	92
	Compost	0	2
CF	Model	24	43
	Compost	0	21
RA	Model	46	59
	Compost	0	0

Those results show a delay of germination of plant embryos during the process of fermentation : the hygienisation is in progress. The « fine »compost presents a delay of germination due to a slower assimilation of compost nutrients: only 21% of the seeds have germinated in des graines ont germé 7 days. It shows then a slight phyto-toxicity due to a lack of maturation he product.

Bacteriological aspects of composts

Analyses of pathogenic micro-organism have been made by an external laboratory. (See Table 9).

Table 5. Bacteriological aspect of compost and jigger discharges.

	CC	CF	RA
Total counting (cfu / g)	1,3.10 ⁷	5,6.10 ⁶	3,9.10 ⁸
Coliforms (/ 100 g)	0	0	4,5.10 ²
E. coli (/ 100 g)	0	0	0
Salmonella (/ 25 g)	Absent	Absent	Absent
Shigella (cfu / g)	0	0	0
Listeria species (25 g)	Present	Absent	Present

The absence of *E. coli* and *Shigella* is noticed for all the samples . The « coarse » compost shows listeria species and the refining discharges of coliforms. The « fine » composts don't show any of those pathogenic agents. The latter is then hygienized, confirming the results of temperature increase in

the swathe, enough for an hygienization, but not for a good degradation. [Mbuligwe *et al.*, 2002]. The compost is not mature enough for an immediate agricultural use according to the tests' results previously obtained. The improvement of fermentation will make it usable in short term.

Agronomical quality of the compost produced

Although the law in force doesn't specify to be sure of the agronomical quality of the compost, those elements are assessed in order to make a judgement on what the compost provides to the soil. Those elements are shown on Table 10.

Table 6. Progress of agronomical quality of compost.

Parameters	CC	CF	RA
P (%)	0.37	0.26	0.28
K ₂ O (%)	0.68	0.73	0.64
CaO(%)	3.00	3.1	3.0
MgO (%)	0.04	0.35	0.33
Na ₂ O (%)	0.74	0.74	0.77

The elements N, P and K are the main nutrients necessary for production rich in humus. Apart from high specific need of some plants or pronounced soil deficiency, the contribution of those 3 elements is enough to cover the needs for cultures fertilization. The composts produced on site are of an agronomical quality comparable to the ones produced in other countries. (Soumaré *et al.*, 2003, Soclo, 1999 ; Ryst, 2001 ; Mbuligwe *et al.*, 2002). The measurement of those elements doesn't replace the validation of the beneficial effect of compost for soils.

Conclusion

In short, the research of simple indicators, reliable and easy to implement so as to assess compost quality must really be suited to production conditions in developing countries. Considering the results obtained, compost produced on site is of average quality. The constituents of the compost studied are sufficient to cover the fertilization needs of cultures. Even if those tests take a long time, they make up an indicator since they are essential for

compost outlets. Finally, in order to ensure compost harmlessness towards toxic metals, other metals (Cr, Hg, As, Se) must be checked during the process.

References

Adani F, Genevini PI, Tambone F. 1995. A new nindex of organic matter stability. *Compost Science & Utilization* **3**, 23-37.

Aina M, Matejka G, Mama D, Yao B, Moudachirou. 2009 Characterization of stabilized waste: Evaluation of pollution risk.

Atkinson CF, Jones DD, Gauthier JJ. 1996. "Biodegradabilities and microbial activities during composting of municipal solid waste in bench-scale reactors". *Compost Science & Utilization* **4(4)**, 4-23.

Avnimelech Y, Bruner M, Ezrony I, Sela R, Kochba M. 1996. Stability indexes for municipal solid waste compost. *Compost Science & Utilization* **4(2)**, 13-40.

Bernal MP, Paredes C, Sanchez-Monedero MA, Cegarra J. 1998. Maturity and stability parameters of compost prepared with a wide range of organic waste. *Bioresource Technology* **63**, 91-99.

Brewer LJ, Sullivan DM. 2003. Maturity and stability evaluation of composted yards trimmings. *Compost Science & Utilization* **11(2)**, 96-112.

Brinton WF. 2000. Compost quality standards & guidelines: An International View. New York, USA, Wood End Research Laboratory. 44.

Brinton WF. 2001. How compost maturity affects plant and roots performance in container grown media. *Journal of biodynamics* **233**, 22-27.

Canet R, Pomares F. 1995. Changes in physical, chemical and physicochemical parameters during the composting of municipal solid waste in two

plants in Valencia. *Bioresource Technology* **51**, 259-264.

Changa CM, Wang P, Watson ME, Hoitink HAJ, Michel FC. 2003. Assessment of the reliability of a commercial maturity test kit for composted manures. *Compost Science & Utilization* **11(2)**, 125-143.

Charnay F. 2005 Compostage des déchets urbains dans les Pays en Développement : élaboration d'une démarche méthodologique pour une production pérenne de compost Thèse donnant le grade de docteur de l'Université de Limoges Faculté des Sciences et Techniques.

Dalzell HW, Biddlestone AJ, Gray KR, Thurairajan K. 1988. Aménagement du sol: production et usage du compost en milieu tropical et subtropical. Rome, FAO.165.

Deportes I, Benoit-Guyot JL, Zmirou D. 1995. Hazard to man and the environment posed by the use of waste urban compost: a review. *The science of the Total Environment* **172**, 197-222.

Francou C. 2003. Stabilisation de la matière organique au cours du compostage de déchets urbains: Influence de la nature des déchets et du procédé de compostage - Recherche d'indicateurs pertinents. Paris, Grignon, Institut National de Recherche Agronomique.

Garcia C, Hernandez T, Costa F, Pascual JA. 1992. Phytotoxicity due to the agricultural use of urban wastes. Germination experiments. *J. Sci. Food Agric.* **59**, 313-319.

Hafid N. 2002. Etude du compost de l'UPAO, des refus de compostage et des anciens dépotoire d'ordures ménagères de la ville d'Agadir". Laboratoire de Chimie minérale et Appliquée et Génie des procédés. Agadir, Maroc, Université IBN ZOHR, Agadir.

Harada Y, Inoko A, Tadaki M, Izawa T. 1981. Maturing process of city refuse compost during piling. *Soil Sci.Plant. Nutr.* **27(3)**, 357-364.

Haug RT. 1993. *The practical handbook of compost engineering.* Boca Raton, Florida, 717.

Helfrich P, Chefetz B, Hadar Y, Chen Y, Schnabl H. 1998. A novel method for determining phytotoxicity in composts." *Compost Science &Utilization* **6(3)**, 6-13.

Hirai MF, Katayama A, Kubota H. 1986. "Effect of compost maturity on plant growth." *BioCycle* **27**, 58-61.

Houot S, Francou C, Lineres M, Le Villio M. 2002. Gestion de la maturité des composts : conséquence sur leur valeur amendante et la disponibilité de leur azote - première partie-. *Echo MO* **34**, 3-4.

Iannotti DA, Grebus ME, Toth BL, Madden IV, Hoitink AJ. 1994. "Oxygen respirometry to assess stability and maturity of composted municipal solid waste." *J. Environ. Qual.* **23**, 1177-1183.

Iglesias-Jimenez E, Perez Garcia V, Espino M, Hernadez JM. 1993. City refuse compost as a phosphorus source to overcome the P-fixation capacity of sesquioxide-rich soils. *Plant and Soil* **148**, 115-127.

Kirchmann H, Widen P. 1994. Separately collected organic household wastes". *Swedish J.agric. Res.* **24**, 3-12.

Larsen KL, McCartney DM. 2000. Effect of C/N ration on microbiol activity and N retention in benchscale study usine pulp and paper biosolids. *Compost Science & Utilization* **8(2)**, 147-159.

Lucero-Ramirez B. 2000. The Effects of Time and Temperature on the Fate of Pathogens and

Indicator Bacteria During Municipal Wastewater Sludge - Mesophilic Anaerobic Digestion, Air-Drying, and Composting". Austin, Texas (United-States), The University of Texas: 205.

Matejka G, De Las HF, Klein A, Paquetteau F, Barbier L, Keke A. 2001. Composting of municipal solid waste in Labé (Guinea): Process optimisation and agronomic development. In *Eight International Waste Management and Landfill Symposium*". Cagliari, Italy. 451-457.

Mbuligwe SE, Kassenga GR, Kaseva ME, Chaggu EJ. 2002. Potential and constraints of composting domestics solid waste in developing countries : findings from a pilot study in Dar es Salaam. *Resources, Conservation and Recycling* **36**, 45-59.

Meoun N, Le Clerc F. 1999. Identification des sources de métaux lourds dans les OM." Paris, Creed. 35.

Miquel M. 2001. Rapport sur les métaux lourds et leurs effets sur l'environnement et la santé. Paris, Sénat. 365.

Mustin M. 1987. *Le compost.* Paris, France, 954.

Noble R, Roberts SJ. 2003. A review of the literature on eradication of plant pathogens and nematodes during composting, diseases suppression and detection of plant pathogens in compost. *The Waste and Resources Action Programme (W.R.A.P).* Novembre 2003. 42.

Rivero C, Chirenje T, Ma LQ, Martinez G. 2004. Influence of compost on soil organic matter quality under tropical conditions." *Geoderma* **123 (3-4)**, 355-361.

Ryst I. 2001. Assessment of a decentralised composting scheme in Dhaka, Bangladesh Technical, operational, organisational and financial aspects." Zurich, Suisse, Sandec. 88.

Sadaka S, EL-Taweel A. 2003. Effects of aeration and C: N Ratio on household waste composting in Egypt." *Compost Science & Utilization* **11(1)**, 36-40.

Sanchez-Monedero MA, Roig A, Paredes C, Bernal MP. 2001. Nitrogen transformation during organic waste composting by the Rutgers system and its effects on pH, Ec and maturity of the composting mixtures. *Bioresource Technology* **78**, 301-308.

Soclo HH, Aguewe M, Adjahossou BC, Houngue T, Azontonde AH. 1999. "Recherche de compost type et toxicité résiduelle au Bénin." *TSM* **9**, 68-76.

Sogreah. 2001. Solid waste management study for Bangkok. Bangkok, Kingdom of Thailand, Bangkok Metropolitan Administration. May 2001.

Soumare M, Tack FMG, Verloo MG. 2003. Effects of a municipal solid waste compost and mineral fertilization on plant growth in two tropical agricultural soils of Mali. *Bioresource Technology* **86**, 15-20.

Tiquia SM, Tam NFY. 1998. "Composting pig manure in Hong Kong." *Biocycle* **39(02)**, 78-79.

Wang P, Changa CM, Watson ME, Dick WA, Chen Y, Hoitink HAJ. 2004. Maturity indices for composted dairy and pig manures. *Soil biology & biochemistry* **36(5)**, 767-776.

Wei YS, Fan YB, Wang MJ, Wang JS. 2000. Composting and compost application in China. *Resources, Conservation and Recycling* **30**, 277-300.

Wu L, Ma LQ, Martinez GA. 2000. Comparison of methods for evaluating stability and maturity of biosolids compost." *J. Environ. Qual.* **29**, 424-429.

Zurbrugg C, Drescher S, Rytz I, Maqsood AH, Enayetullah I. 2005. Decentralised composting in Bangladesh, a win-win situation for all stakeholders." *Resources, Conservation and Recycling* **43(3)**, 281-292.